

CBR3-M & CBR-3L

Condensing Unit Support Brackets Type 3 Installation instructions



Pump House
Glaisdale Drive East
Nottingham
NG8 4LY
Tel: 0115 900 5858

sales@pumph.co.uk
www.pumph.co.uk



CBR3-M & CBR3-L - Type 3 Brackets Installation Instructions

BRACKET STRUCTURE COMPONENTS

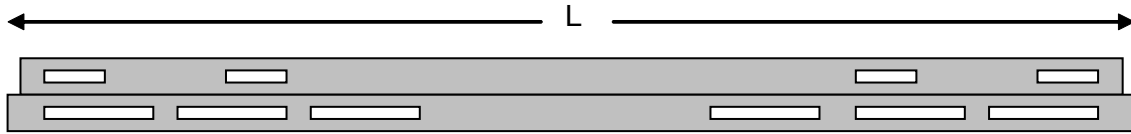

A - Crossbar

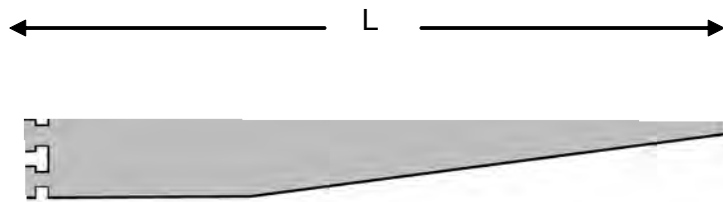

B - Support Arm

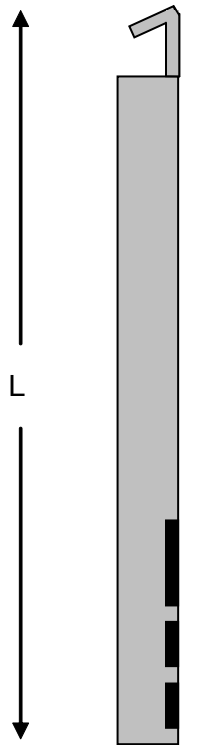

C - Upright

CBR3-M & CBR3-L - Type 3 Brackets Installation Instructions

COMPONENTS

Pump House Condensing Unit Support Brackets are designed to support all leading brands of air conditioning condensing units and air source heat pumps, and have been independently tested and certified to the above safe working loads, subject to the correct assembly and use of the product. Pump House accepts no liability for failure of this product where it has been assembled incorrectly or has been used for a function outside its intended application.

LIST OF COMPONENTS				
Item	Qty.	Description	Length, L (mm)	
			CBR3-M	CBR3-L
A	1	Crossbar	900	1040
B	2	Support Arm	500	540
C	2	Upright	500	550
E	4	M8 Wall-Fixing Bolts		
G	4	M8 x 30mm Bolt		
H	2	M8 x 20mm Bolt		
I	4	20mm Washer		
J	8	25mm Washer		
K	6	M8 Nut		
M	4	Anti-Vibration Washer		
N	2	Wall-Spacer		

INSTALLATION INSTRUCTIONS

1. Mark and drill the wall with four 10mm holes at locations corresponding to the fixing holes provided in the bracket crossbar (A).
2. Fix the crossbar (A) to the wall using 4 x wall-fixing bolts (E)
Fit the support arms (B) to the uprights (C) by positioning the teeth of the arms into the corresponding slots in the uprights. (see note 7.)
3. Screw-in fully the wall-spacers (N) to the thread at the bottom rear of the uprights (C).
4. Attach the upright (C) to the crossbar (A) using 2 x M8 x 20mm bolts (H), 4 x 20mm washers (I), 2 x M8 nuts (K). The horizontal distance between these fixing positions should be the same as the distance between the feet of the condensing unit.
5. Fix the feet of the condensing unit to the support arms (B) using 4 x M8 x 30mm bolts (G), 8 x 35mm washers (J), 4 x M8 nuts (K) and 4 anti-vibration washers (M).
6. Adjust the wall-spacers (N) to ensure that the condensing unit unit is supported in a horizontal position.
7. **The upright sections of these brackets include a small 'lock-tab', which protrudes approximately 3.6mm from the surface. This is designed to prevent the bracket arm being dislodged accidentally after installation. This lock-tab will offer some resistance when the arm is fitted to the upright; this is normal.**

The installer can adjust this lock-tab by levering it with a screwdriver; this enables the installer to confirm that the joint has locked correctly, or to disassemble the bracket if required.
8. **Sea salts are very corrosive and affect both ferrous and non-ferrous metals. Coastal installations are particularly at risk as they are frequently exposed to sea salt solutions followed by dry periods, where this wet/dry cycle produces a very corrosive environment. We strongly recommend that in such locations only our stainless steel brackets are installed.**

CBR3-M & CBR3-L “EASY~FIT” Installation Instructions

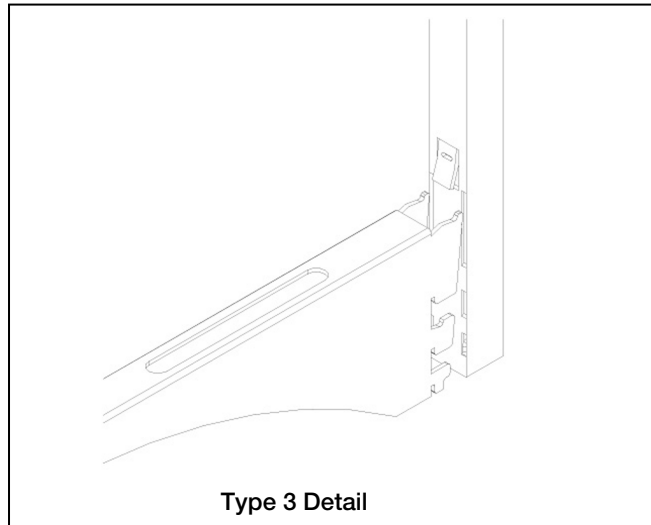
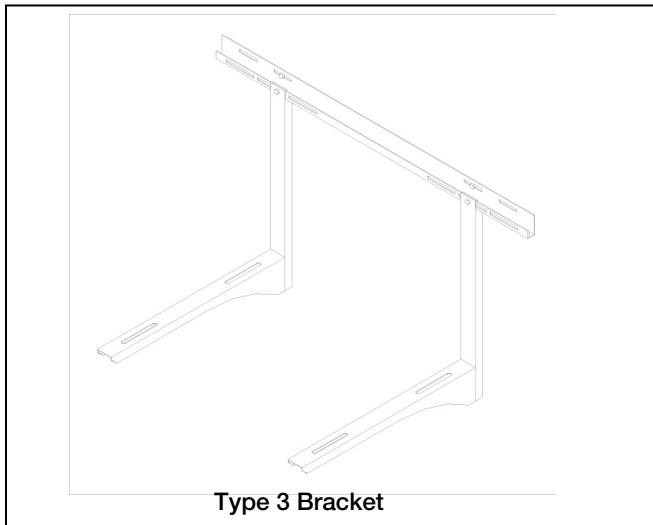

SPAN OF SUPPORT ARMS

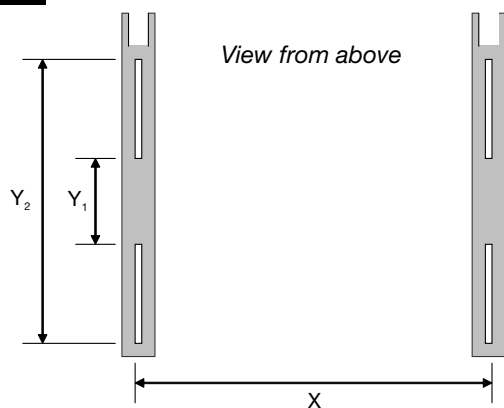

Dimensions for span of condensing unit feet

Model	Width of Unit		Depth of Unit	
	Minimum (X)	Maximum (X)	Minimum (Y ₁)	Maximum (Y ₂)
CBR3-M	245mm	800mm	125mm	425mm
CBR3-L	300mm	940mm	170mm	470mm

Model	Maximum Safe Working Load
CBR3-M	90kg
CBR3-L	140kg

GUIDANCE ON INSTALLATION

1. This product should be fitted by a competent installer.
2. Pump House Condensing Unit Support Brackets are designed for use with all makes of condensing unit. Ensure that the bracket you have ordered is suitable for your condensing unit by referring to the safe working load and unit dimension tables.
3. The purpose of this product is to support air conditioning, refrigeration and air source heat pump
4. Ensure wall or building fabric is capable of supporting the load.

For further installation advice please call the technical support helpline on 0115 900 5858.